



DR 50

DEUMIDIFICATORE PROFESSIONALE
PROFESSIONAL DEHUMIDIFIER

DR 50

- Scheda elettronica di controllo con display grafico
 - Diagnostica grafica interattiva
 - Termostato digitale incorporato
 - Contatore parziale resettabile e totale
 - Cavo alimentazione elettrica con spina
 - Autospegnimento programmabile
 - Indicatore luminoso/acustico serbatoio pieno
 - Riarmo automatico in caso di cali od interruzione di corrente di alimentazione
 - Compressore ermetico rotativo
 - Sbrinamento automatico per basse temperature ad iniezione di gas caldo
 - Vaschetta di raccolta dell'acqua
 - Eco friendly gas conformity 2020 EU Regulation
 - Possibilità di scarico diretto mediante kit evacuazione acqua (accessorio a richiesta)
 - Maniglia tubolare telescopica
 - La carrozzeria è interamente realizzata con lamiera zincata verniciata
 - Ruote in gomma antimacchia
 - Tutti i modelli della serie sono facilmente sovrapponibili per un pratico ed efficace immagazzinamento
- *Electronic control board with graphic display*
 - *Interactive graphic diagnostics*
 - *Built-in digital thermo*
 - *Partial resettable and total counter*
 - *Power supply cable with plug*
 - *Programmable auto-off*
 - *Full tank light / acoustic indicator*
 - *Automatic reset in case of power drops or interruptions*
 - *Hermetic rotary compressor*
 - *Automatic defrost for low temperatures by injection of hot gas*
 - *Water collection tray*
 - *Eco friendly gas conformity 2020 EU Regulation*
 - *Possibility of direct discharge thanks to a gasket kit (accessories on demand)*
 - *Telescopic tubular handle*
 - *The body is made entirely of painted galvanized sheet metal*
 - *Stain-resistant rubber wheels*
 - *All the models in the series can be easily stacked for practical and effective storage*



ACCESSORI A RICHIESTA / ACCESSORIES ON DEMAND

<p>KIT TUBO EVACUAZIONE ACQUA CON PORTAGOMMA E GUARNIZIONE WATER PIPE WITH CONNECTION AND GASKET KIT</p>	<p>KIT STAFFE A MURO WALL SUPPORT KIT</p>
	
<p>Mod. l= 6 m Cod. 06AC111</p>	<p>Cod. 06AC113</p>
<p>KIT POMPA EVACUAZIONE CONDENSA COMPLETO DI TUBO* CONDENSATION PUMP KIT WITH HOSE INCLUDED*</p>	<p>KIT RUOTE PIVOTTANTI CON FRENO SWIVELLING WHEELS WITH BRAKE</p>
	
<p>Cod. 06AC119</p>	<p>Cod. 06AC122</p>
<p>KIT MANDATA ARIA RISCALDATA A 2 TUBI TWO PIPES HEATED AIR OUTLET KIT</p>	<p>TUBO DI MANDATA ARIA OUTLET PIPE</p>
	
<p>Cod. 06AC115</p>	<p>Cod. 02AC577*</p>

* Codice riferito a 1 singolo pezzo - Code referred to 1 single piece

** Da sostituire alla vaschetta acqua - To replace the water collection tray

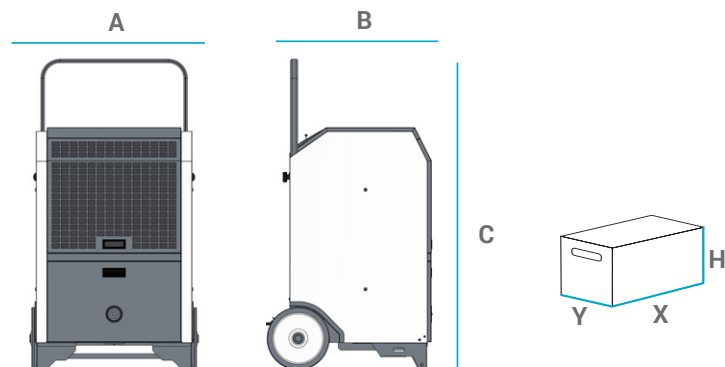

PESI E DIMENSIONI MACCHINA WEIGHTS AND DIMENSIONS MACHINE					IMBALLO PACKAGING			
MOD	A	B	C	Netto/Net	X	Y	H	Lordo/Gross
	[mm]	[mm]	[mm]	[kg]	[mm]	[mm]	[mm]	[kg]
DR 50	568	554	777	55	630	605	920	65

MODELLO - MODEL		DR 50	DR 50 DUAL VOLTAGE
codice - code		06DE131	06DE331
range temperatura (campo di funzionamento) - temperature range (operating working)	[°C]	3 - 40	
range umidità (campo di funzionamento) - humidity range (operating working)	[%]	20 - 100	
capacità deumidificazione - dehumidification ability (@ 32°C - 90%)	[l/24h]	52,39	
capacità deumidificazione - dehumidification ability (@ 30°C - 80%)	[l/24h]	45,08	
capacità deumidificazione - dehumidification ability (@ 15°C - 70%)	[l/24h]	19,80	
portata aria - air flow	[m³/h]	450	
capacità vaschetta acqua - water container capacity	[l]	17	
alimentazione elettrica - power supply	[V, ~, Hz]	230, 1, 50	110/230, 1, 50
potenza elettrica assorbita max - max electrical power (@ 32°C - 90%)	[W]	890	
consumo energetico specifico - specific energy consumption (@ 32°C - 90%)	[kWh/liter]	0,41	
consumo energetico specifico - specific energy consumption (@ 30°C - 80%)	[kWh/liter]	0,47	
consumo energetico specifico - specific energy consumption (@ 15°C - 70%)	[kWh/liter]	0,67	
refrigerante - refrigerant		R454C	
tipo compressore - compressor type		rotativo - rotary	
classe di protezione - protection class		IP X4	
livello sonoro a 1 metro - sound level at 1 meter	[dBA]	59	